

Approved Cable Suppliers				
Item #	Supplier name	Part Number	UL #	Raw cable jacket mark
1	PALCONN	4A90622001		NO MARK
2	PALCONN	3B00118018		NO MARK
3	PALCONN	3B00118019		NO MARK
4	PALCONN	3B00118020		NO MARK
5	PALCONN	3B00118021		NO MARK
6	PALCONN	3B00118022		NO MARK

REVISION	INITIALS	REASON	DATE	F	LGH	BOM QTY, LABEL TABLE P1	7/19/19
A	LGH	INITIAL RELEASE	8/20/18	G	LGH	SENSOR P/N, NEW P1 CONNECTOR & OVERMOLD	11/12/19
B	LGH	ADD LABEL, UPDATE WIRE TABLE	12/4/18	H	LGH	ITEM #7 WIRE COLOR	12/11/19
C	LGH	DETAIL A	4/24/19	I	LGH	CUSTOMER PART NUMBER	12/19/19
D	LGH	CONNECTOR COLOR/STRAIN RELIEF	5/14/19	J	LGH	ITEM#20 POTTING & NOTES	03/23/20
E	LGH	PCB/EEPROM NOTES, DETAIL A	7/8/19	K	LGH	P1 CONNECTOR P/N CHANGE/KEYWAY CHANGE B TO A	04/20/20
D	LGH	CONNECTOR COLOR/STRAIN RELIEF	5/14/19	L	LGH	UPDATE DETAIL A	04/27/20
				M	LGH	UPDATE BOM ITEM#20-22	09/18/20

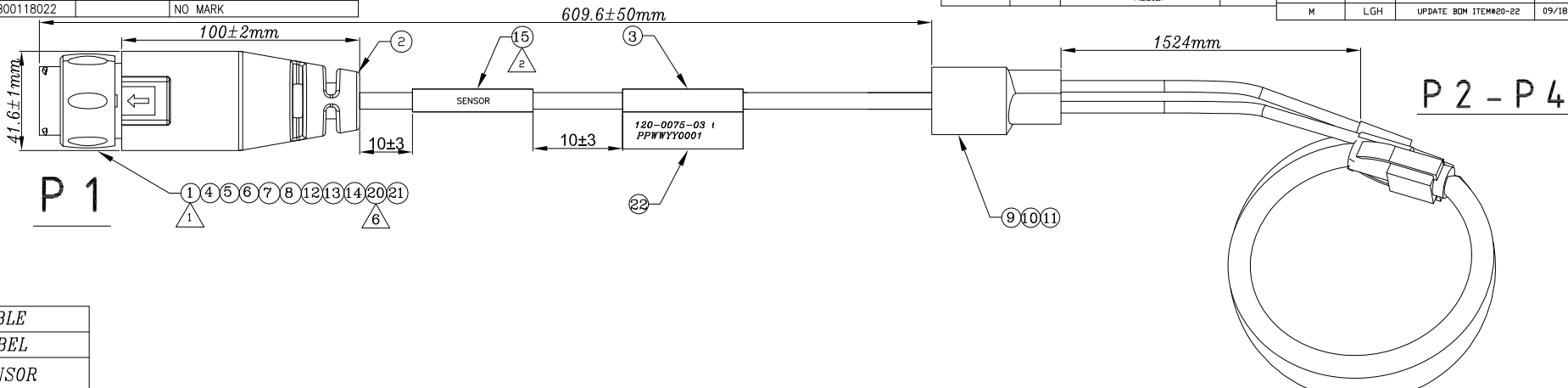
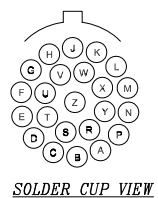

LABEL TABLE	
CONN	LABEL
P1	SENSOR
P1	P/N 120-0075-03 6 PPWYY0001
P2	PHASE A
P3	PHASE B
P4	PHASE C

22	LABEL	1PC	L:75.0MM*W:30.0M PE MATERIAL WHITE BACKGROUND AND BLACK WORDS.
21	GLUE	AR	LOCTITE P/N: EA E-30CL-EN
20	GLUE	AR	KAPUTER P/N: K-5096L
19	LABEL	3PCS	STICKER, LOAD ARROW,
18	SENSOR	1PC	SENSOR ROGO, UM1, BLUE (P4) P/N: JRFS-120S-IP68-3M_BLUE
17	SENSOR	1PC	SENSOR ROGO, UM1, WHITE (P3) P/N: JRFS-120S-IP68-3M_WHITE
16	SENSOR	1PC	SENSOR ROGO, UM1, RED (P2) P/N: JRFS-120S-IP68-3M_RED
15	SHRINK TUBE	AR	TUBING, HEAT SHRINK, PRINTABLE, 19mm BLACK/WHITE PALCONN P/N: CB0010P00012
14	SHRINK TUBE	AR	HEAT-SHRINK TUBING, ID 2.3mm BEFORE SHRINKING 25FT PALCONN P/N:
13	SHRINK TUBE	AR	HEAT-SHRINK, .48" x 2.5" LG PALCONN P/N: CB0010P00017
12	PCBA	1PC	PCBA, EEPROM BOARD, CABLE ID
11	CRIMPING TERMINAL	6PCS	BUTT SPLICE, SOLDER SLEEVE, 22-24 AWG PALCONN P/N: CB0010P00019
10	CABLE SEPARATOR	1PC	CABLE SPLITTER, HEAT SHRINK PALCONN P/N: CB0010P00018
9	SHRINK TUBE	AR	19MM SHRINK TUBE, ADHESIVE LINED PALCONN P/N: CB0010P00014
8	CABLE	1PC	BLUE 18AWG 1C*18AWG L: 30±2MM PALCONN P/N: 3B00118022
7	CABLE	1PC	BROWN 18AWG 1C*18AWG L: 30±2MM PALCONN P/N: 3B00118019
6	CABLE	1PC	YELLOW 18AWG 1C*18AWG L: 30±2MM PALCONN P/N: 3B00118020
5	CABLE	1PC	GREEN 18AWG 1C*18AWG L: 30±2MM PALCONN P/N: 3B00118021
4	CABLE	1PC	RED 18AWG 1C*18AWG L: 30±2MM PALCONN P/N: 3B00118018
3	CABLE	AR	3P*22AWG+F+AL+D+B OD: 6.8±0.2MM XL-PE(MOISTURE CURED) BLACK
2	OVERMOLD	AR	MATERIAL: TPE BLACK 88A ZHONGXU P/N: MSLTPE00WR021
1	CONNECTOR	1PC	BIX P/N: FS4MBLA23M00.1500 (RECEPTACLE)

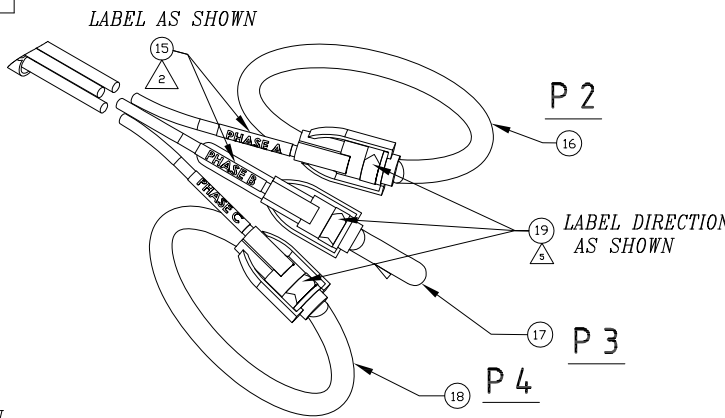
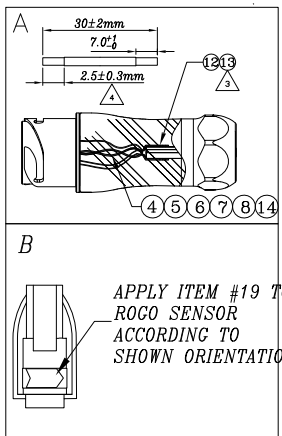

ITEM	PART NAME	Q'TY	PART NO
GENERAL TOLERANCE ANGLE TOLERANCE			
X.	±1.00	X°	±3.0°
.X	±0.50	.X°	±1.0°
.XX	±0.20	.XX°	±0.5°
.XXX	±0.15		
MAJOR(QC CHECKED)	SCALE 1 : 1	APPROVED:	DATE
▼ = 8 places		LCZ	2020/09/18
CRITICAL =	UNIT mm	CHECKED:	DATE
SHEET 1 OF 2		DESIGN:	DATE
		LGH	2020/09/18

PALCONN

CUSTOMER P/N:
120-0075-03

TITLE:
CABLE ASSY UM3+ KRAKEN

SERIES: SIZEA4

DRAWING NO:70 A005 SENT R024CN REV M